

# PANIC / FIRE EXIT SURFACE MOUNTED VERTICAL ROD DEVICES

## INSTALLATION INSTRUCTIONS

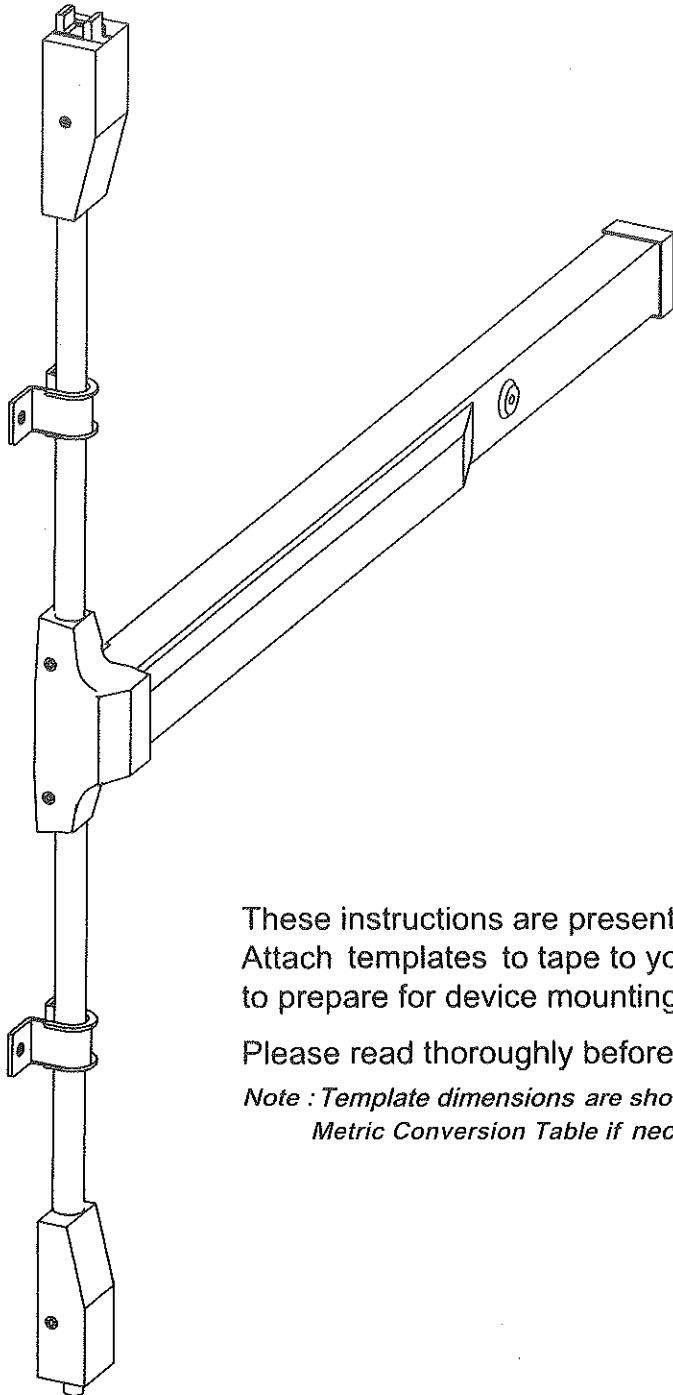

These instructions are presented in step by step sequence. Attach templates to tape to your door and frame as an aid to prepare for device mounting.

Please read thoroughly before installation.

*Note : Template dimensions are shown in inches. See attached Metric Conversion Table if necessary.*

# DESIGNATION OF PARTS

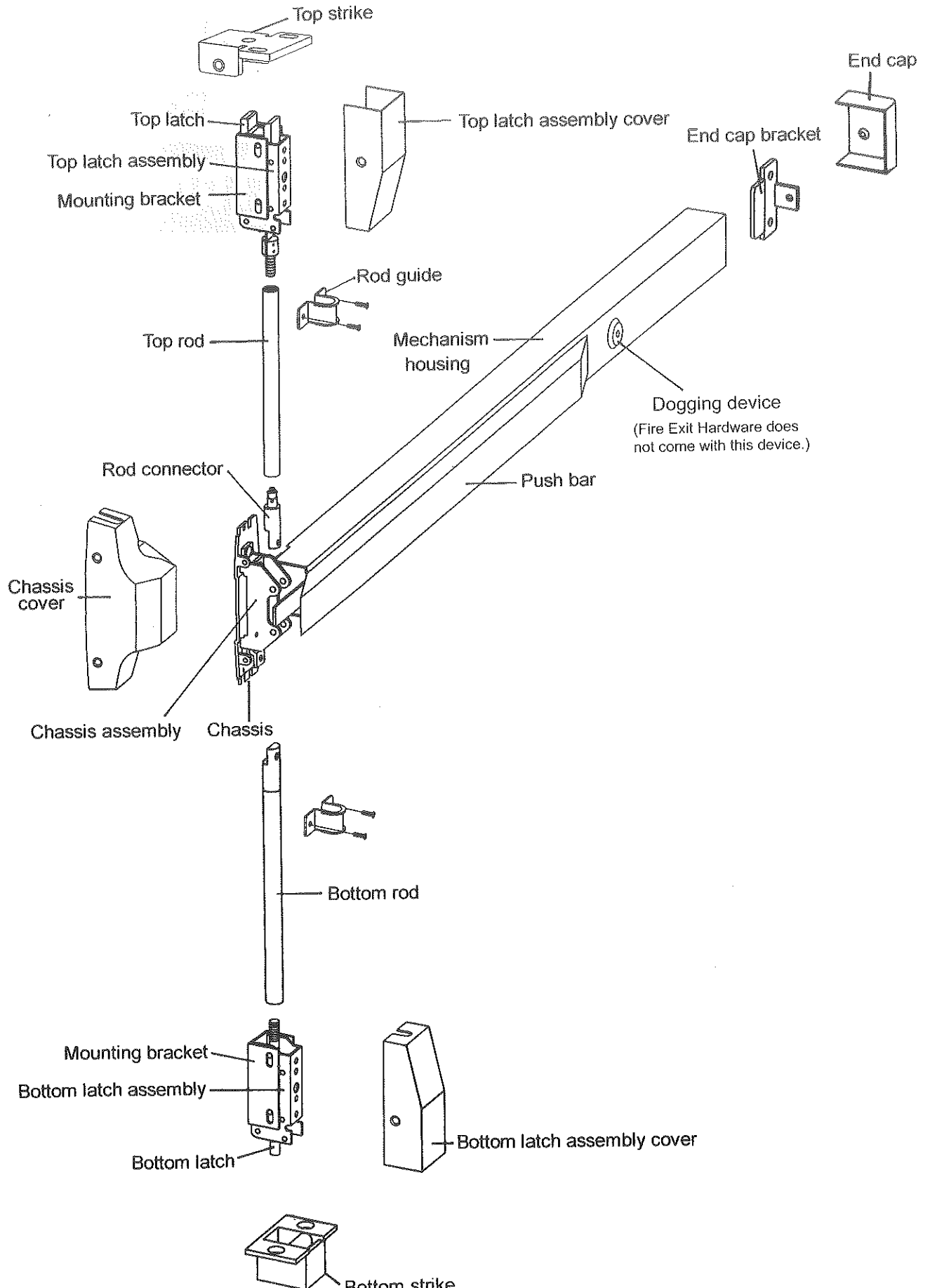

## STEP 1: PREPARE DOOR

1. Mark position of holes on the door with templates. (See Figure 1.)
2. Spot and drill all holes as marked on door for device chassis, top & bottom latch mounting brackets, and end cap bracket.

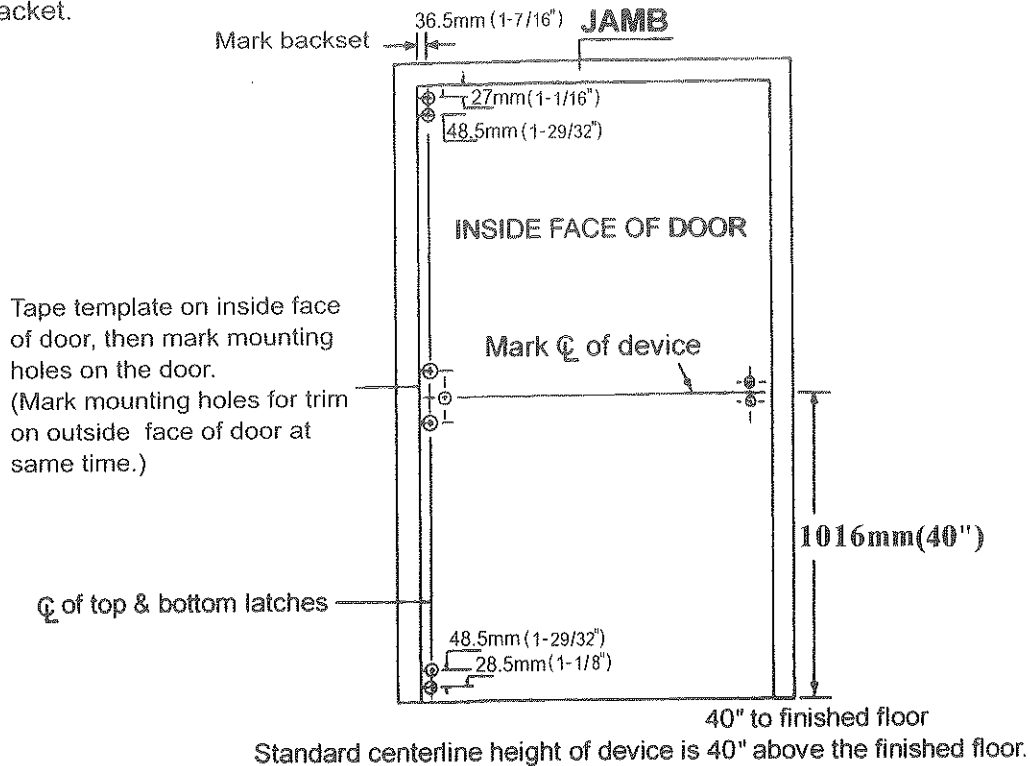

Figure 1

## STEP 2: INSTALL BRACKETS, DEVICE & TRIM

1. Remove chassis cover from chassis assembly and end cap from end cap bracket.
2. Cut the length if required.

The length of devices are precut for 36" and 48" wide door use, no additional cutting is necessary. If narrow door installation is needed, cut device "A" equal to door width minus 4" to fit properly.

**Note:**

*If cutting is necessary, device must be cut plain and clean all burrs for proper end cap fit.*

3. Mount device horizontally to the drilled position securely with supplied mounting screws, or bolt device chassis to trim with sex bolts if required. (See Trim Installation Instructions.)
4. Make sure trim actuating shaft can be inserted into device cam. (Ref. View "+" for cam description.)
5. Install end cap bracket on device then screw to door. (Make sure device is level.)
6. Install two mounting brackets on top and bottom of the door. (See Figure 2.)

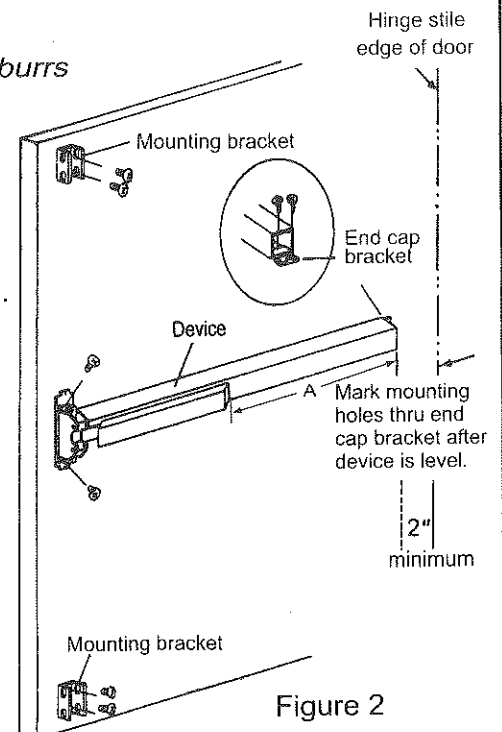
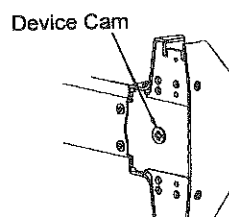
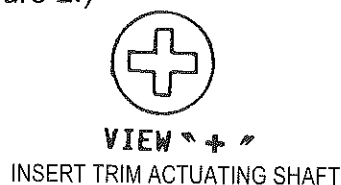
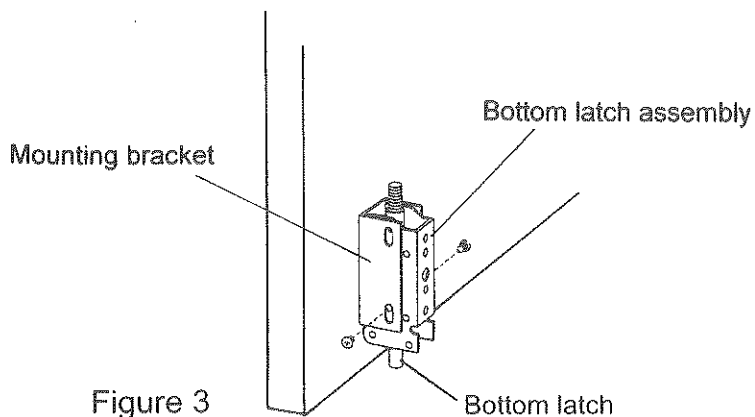

Figure 2

### STEP 3 : INSTALL BOTTOM ROD AND BOTTOM STRIKE

1. Mount bottom latch assembly into mounting bracket. (See Figure 3.)



2. Fasten the driving pin into upper side of bit glide plate as shown in Figure 4.

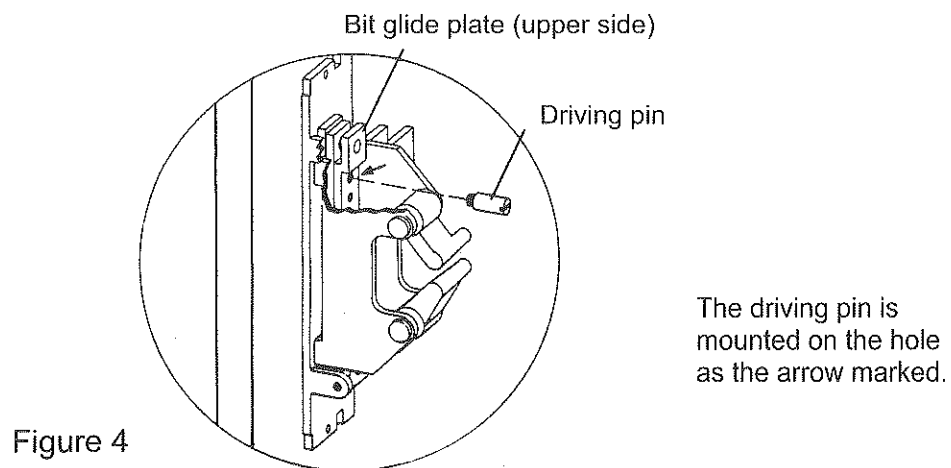

3. Screw the threaded end of bottom rod into bottom latch assembly. (See Figure 5.)

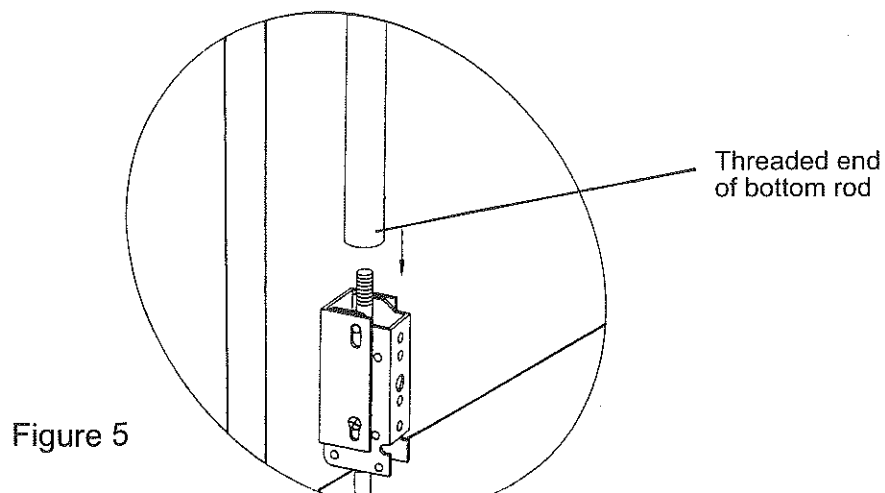

4. Tighten bottom rod with bit glide plate which should be in the down position as shown in Figure 6.

*Note : If the hole on bottom rod connector does not match alignment with the mounting hole of bit glide plate, adjust the height of bottom rod as shown in Figure 5.*

5. Install bottom strike into finished floor and be sure to align center line of bottom latch with center line of bottom strike. (See Figure 7.)

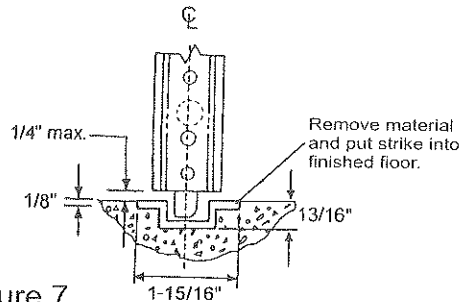
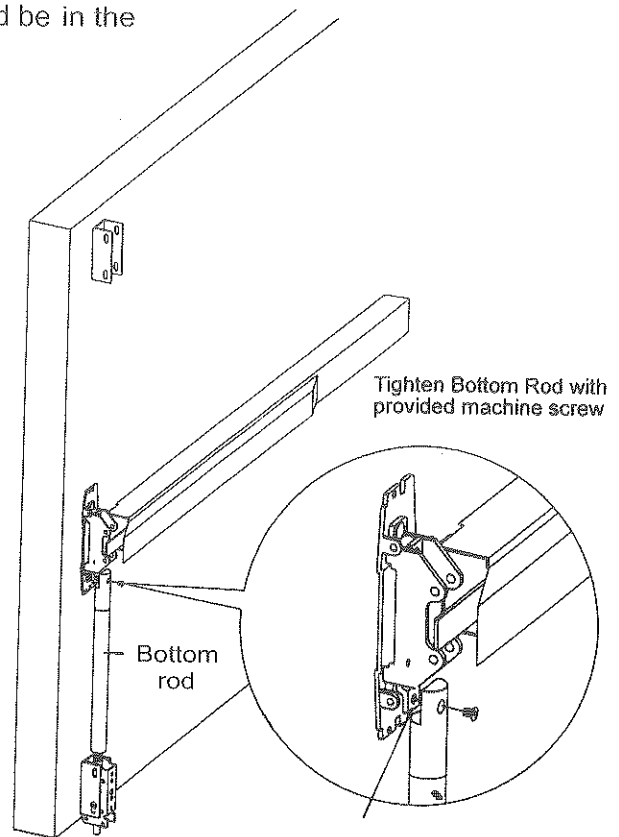

Figure 7

6. Depress push bar and release to check for correct installation:

6-1 Make sure bottom latch can be held retracted and flush with the edge of door when push bar is depressed.

6-2 Check bottom latch bolt to make sure it has (9.5mm) throw minimum when push bar is released.



Bit glide plate (lower side)

Figure 6

## STEP4 : INSTALL TOP ROD AND TOP STRIKE

1. Mount top latch assembly into mounting bracket. (See Figure 8.)
2. Screw the threaded end of top rod into top latch assembly completely. (See Figure 9.)

**NOTE:**  
Latch should be in locked position as shown.

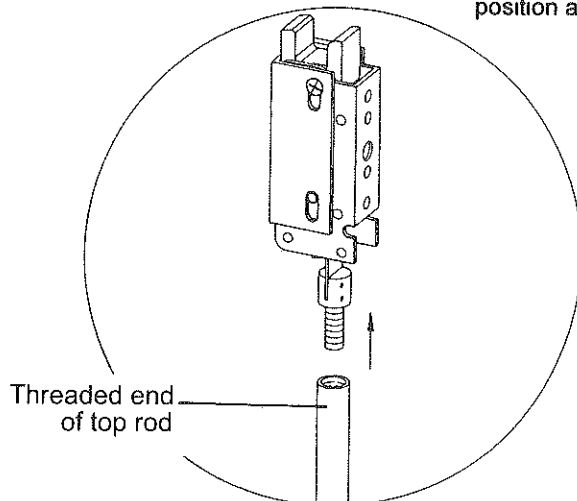

Threaded end of top rod

Figure 9

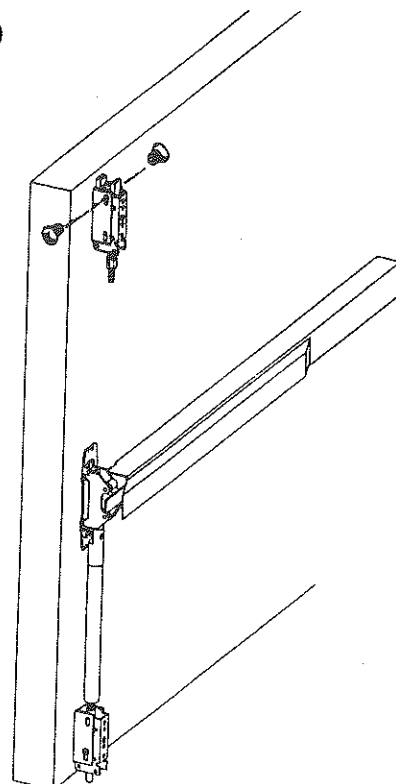

Figure 8

3. Measure and cut the length of top rod. The length of top rod is measured to the edge of rod connector which will be fastened on arrow mark position of chassis assembly in next step. Mark cutting line then cut the excess portion. (See Figure 10.)
4. Insert rod connector into the non-threaded end of top rod and fasten the setting screw securely. (See Figure 11.)

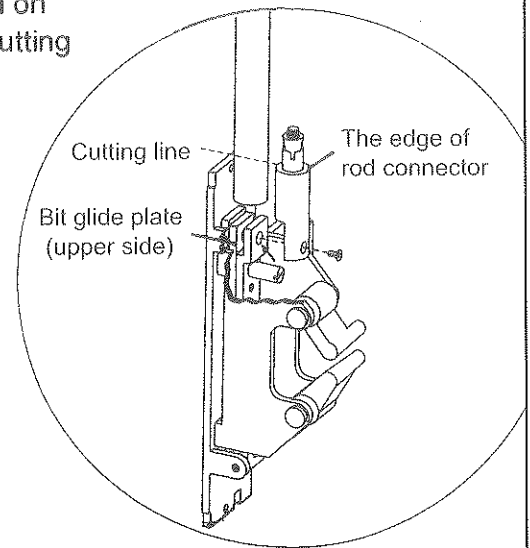

Figure 10

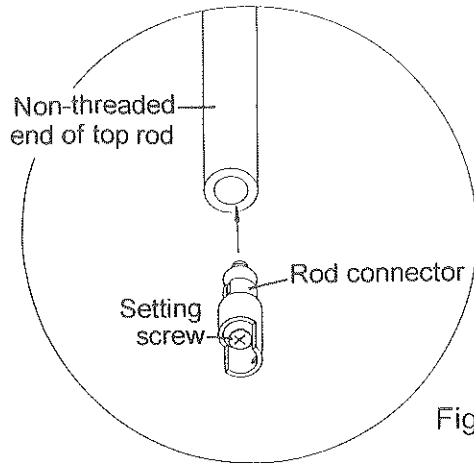

Figure 11

5. Tighten top rod with rod connector onto the bit glide plate (upper side), see Figure 12.

**Note :** If the hole of top rod connector does not match in alignment with the mounting hole of bit glide plate, adjust the height of top rod as shown in Figure 9 or re-cut the length.

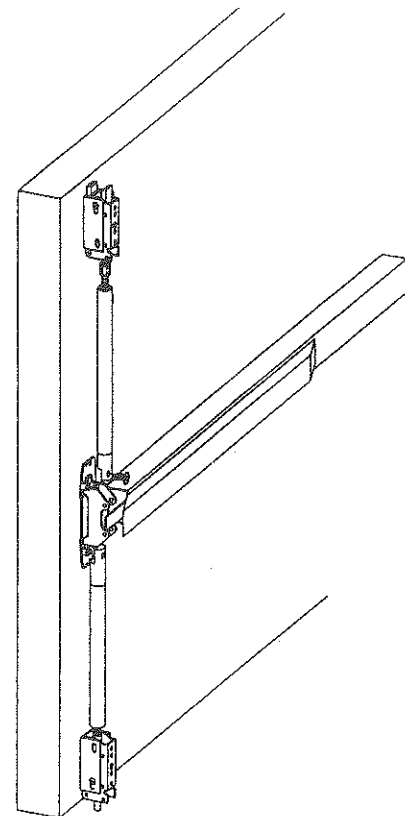

Figure 12

6. Mark mounting holes for top strike on jamb with Strike Template (see Figure 13) then fasten with supplied screws. (See Figure 14.)

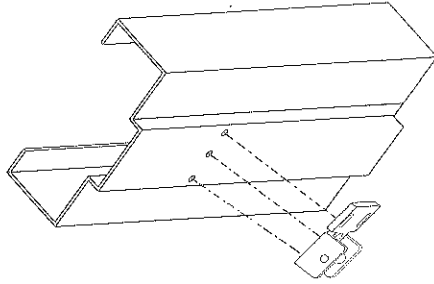

Figure 13

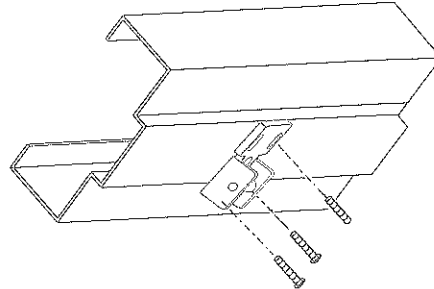

Figure 14

### STEP 5 : TEST OPERATION

1. Depress push bar, top latch should be held retracted. While top latch bolt is retracted, the bottom latch must clear floor and strike simultaneously to open door.
2. Release push bar, both top latch bolt and bottom latch bolt should be full extended.
3. Check device operation by depressing and releasing push bar several times to assure correct installation.
4. Repeat device operation by opening and closing door several times with outside trim to make sure installation is correct.
5. Repeat adjustment procedure if either top latch bolt is not held retracted or bottom latch bolt does not clear floor and strike.

### STEP 6 : INSTALL COVERS

1. Before installing covers, make sure to secure latch bolts and adjust strikes if required.
2. Install chassis cover, end cap, both top and bottom latch covers. Then install two rod guides into the positions as shown. (See Figure 15.)

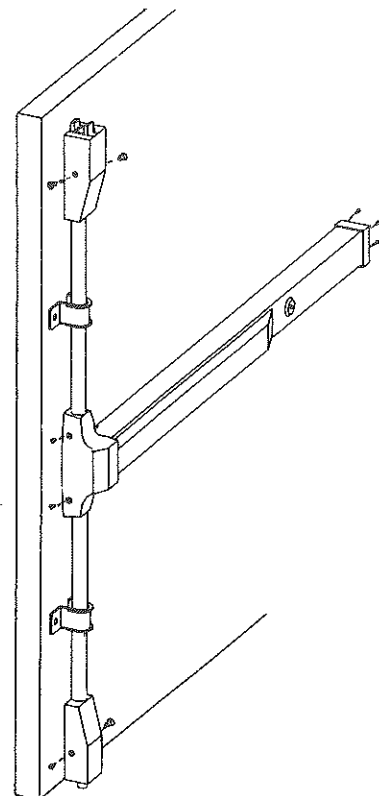
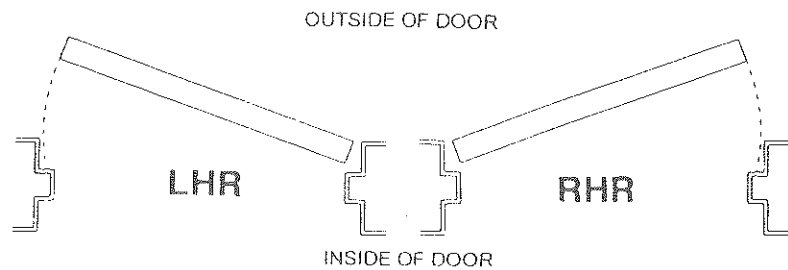

Figure 15

## Door Handing

Use the diagram to determine the hand of door.



## NOTE:

***Dogging device during high traffic period of the day will greatly extend life of this device. (A dogging device is not available on fire models as fire door must remain closed and latched.)***

### Dogging:

Depress push bar,  
insert dogging wrench  
and turn clockwise 90°

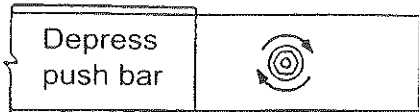

The push bar will remain pressed and the latches will keep retracted.

### Release dogging:

Depress push bar,  
insert dogging wrench and  
turn counter-clockwise 90°

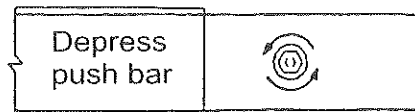

The push bar will return to up position and the latches will project to lock the door.

Dogging wrench

